

USER GUIDE

PERFORM RISK ASSESSMENT FIRST



SAFETY IS PARAMOUNT.
Machinery and conditions can change from site to site so it is essential to ensure a risk assessment is completed for each application, in accordance with your Workplace Health & Safety requirements.



INSPECT YOUR TRAY SUPPORT BLOCKS

Ensure you inspect all Tray Support Blocks prior to use, for damage that may affect its safe operation.

If there are any signs of damage, discard item & **DO NOT USE.**



TEMPERATURE OF YOUR TRAY SUPPORT BLOCKS



DO NOT USE Tray Support Blocks if they are above 40°C (104° F) or below -50° C (-58° F).

Note: these temperatures refer to the actual item, not the ambient temperatures



WEIGHT AND IMPACT

Ensure you know the weight of the load being placed on the Tray Support Block.

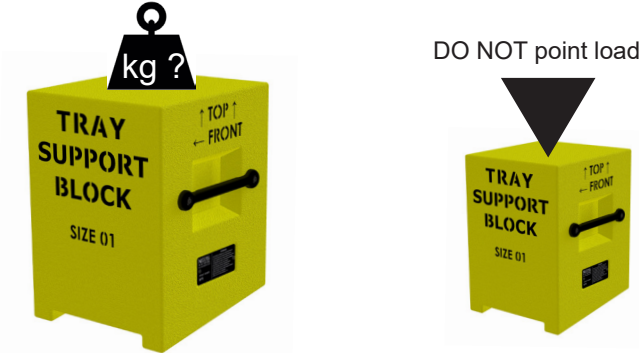

ALWAYS calculate the load area - refer to pages 3- 10 for guide



Always lower the load onto the Tray Support Block carefully.

Impact may create a force greater than the load capacity and damage the block.

WHICH TRAY SUPPORT BLOCK TO USE?

Note 1:

Each block has been designed to suit a particular truck model, however, many trucks have variations during manufacture. Many now have after market trays which vary in weight and size so we are unable to guarantee the truck model compatibility.

The following is a guide for truck suitability but you must confirm the product is suitable for your specific application by conducting your own risk assessment.

SET UP FOR TRAY SUPPORT BLOCK - SIZE 02

PART NO: NPR05233-00

Suits Komatsu 830 - 930 & CAT 793 Wide Chassis Rail
*refer note 1 on page 2

LOAD CALCULATION GUIDE

The load calculation is based on the minimum contact area between the tray support block and each rail surface.
The rails need to be parallel to the block surfaces.

EXAMPLE 1

Chassis rail contact area
 $31\text{cm} \times 35\text{cm} \times 30\text{kg} = 32,550\text{kg}$

Tray rail contact area
 $29\text{cm} \times 35\text{cm} \times 30\text{kg} = 30,450\text{kg}$

In this scenario the result = load rating is **30,450kg per block**

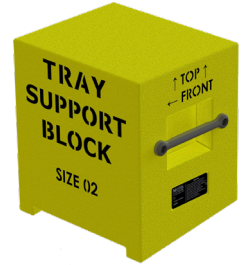

EXAMPLE 2

Chassis rail contact area
 $31\text{cm} \times 35\text{cm} \times 30\text{kg} = 32,550\text{kg}$

Tray rail contact area
 $32\text{cm} \times 35\text{cm} \times 30\text{kg} = 33,600\text{kg}$

In this scenario the result = load rating is **32,550kg per block**

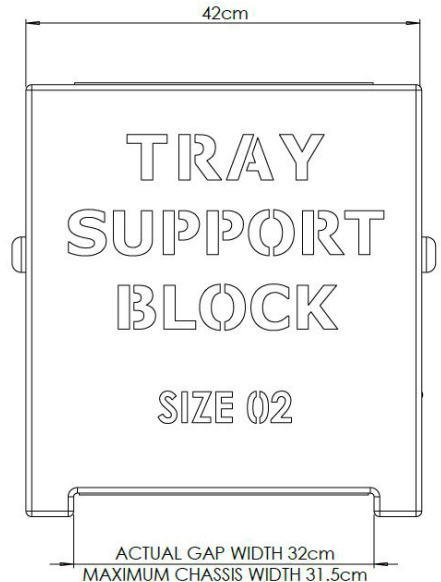
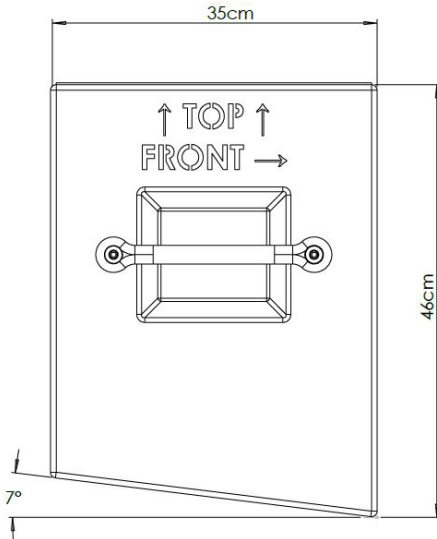

Chassis and tray rails need to be parallel with surfaces of tray support block to ensure full surface contact

As a guide, the angle between the chassis and tray should be 7°

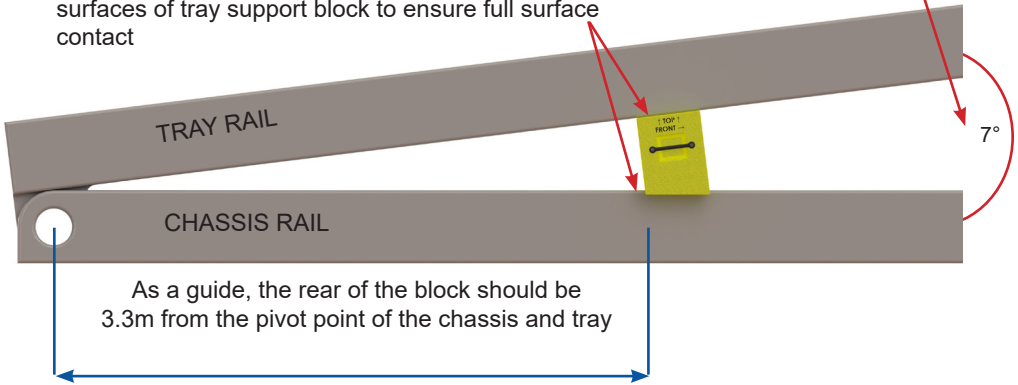

Tray rail contact area

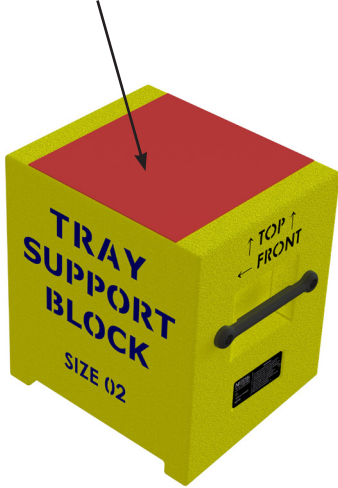

Chassis rail contact area

